

MKP 01 KRÓCIEC

KOD	WYMIARY D/d
01	14/8
02	14/10
03	16/10
04	wg zam.

KOD	MATERIAŁ
01	P245GH/P265GH
02	13CrMo4-5
03	X6CrNiTi18-10
04	wg zamówienia

KOD	KRÓCIEC
01	otwarty
02	ślepy

MKP 01- 01 01 01 PRZYKŁAD ZAM.

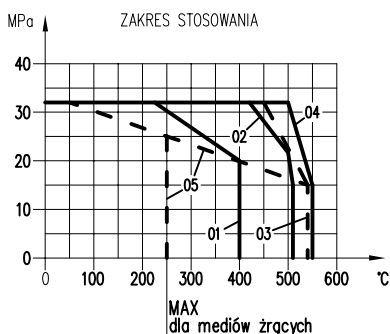
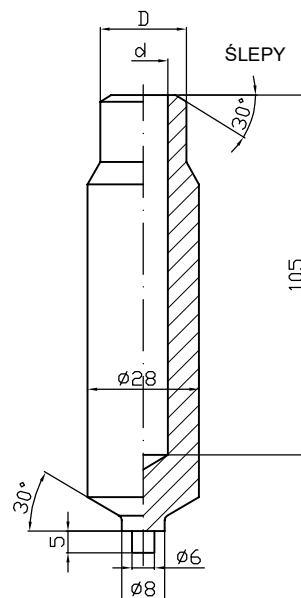
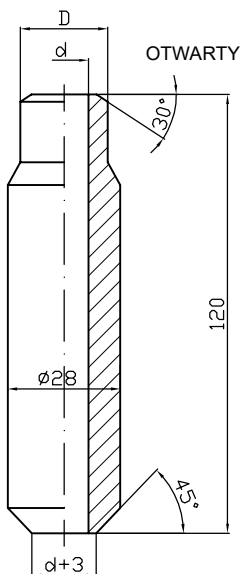

MKP 02 KRÓCIEC

KOD	WYMIARY D/d
01	18/10
02	21,3/15,5
03	24/10
04	wg zam.
05	14/8

KOD	MATERIAŁ
01	P245GH/P265GH
02	13CrMo4-5
03	10CrMo9-10
04	14MoV6-3
05	X6CrNiTi18-10
06	wg zamówienia

KOD	KRÓCIEC
01	otwarty
02	ślepy

MKP 02- 01 01 01 PRZYKŁAD ZAM.